

4

3

2

1

B

B

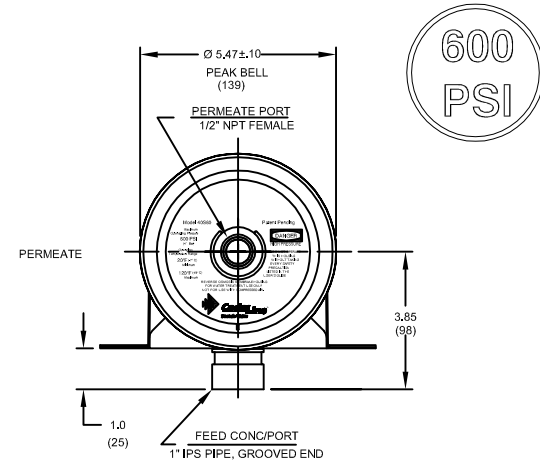
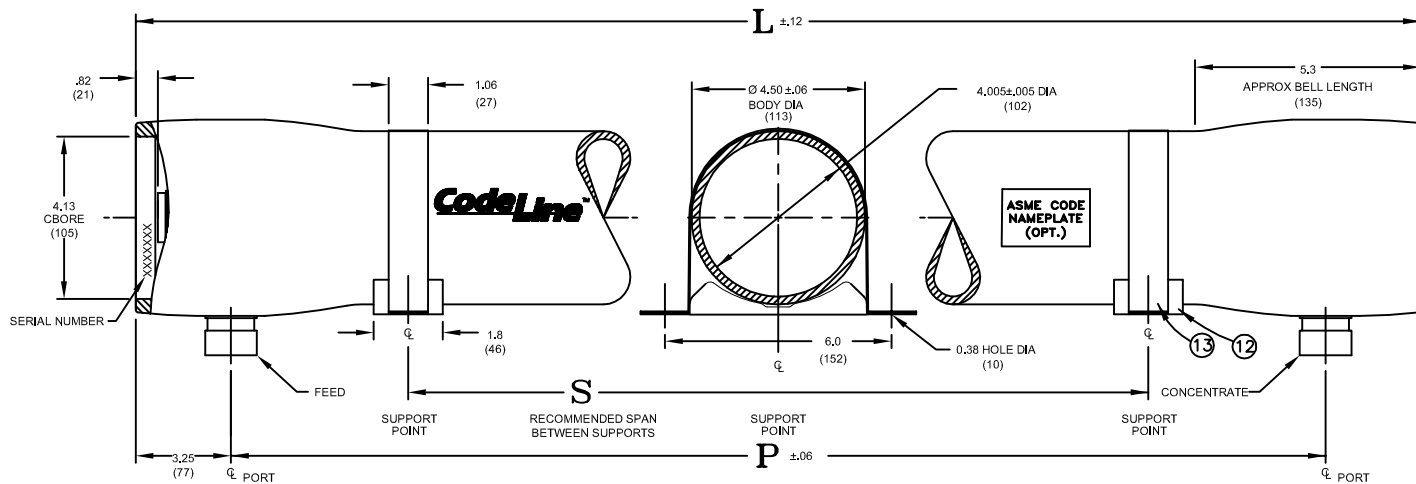

VIEW AT CENTER SUPPORT
 CENTER VESSEL ON 2 OR 3 SUPPORTS
 AT SPAN(S) *S*: 3 SUPPORTS REQUIRED
 FOR LENGTHS -4 AND OVER

DWG REF	QTY	PART NUMBER	DESCRIPTION	MATERIAL
SHELL				
1	1	ORDER SECTION	SHELL	Filament Wound Epoxy/Glass composites - Head locking grooves integrally wound in place.
2	A/R		F/C Port	CF3M*
3	A/R		F/C Port Seal	Ethylene Propylene - Square Cut
4	A/R		F/C Port Retainer	300 Series SST
HEAD				
5	2	96803	Bearing Plate	316 Stainless Steel / Equivalent.
6	2	96855	Sealing Plate	Engineering Thermoplastic.
7	2	45317	Head Seal	Ethylene Propylene - O - Ring
8	2	96807	Permeate Port	Engineering Thermoplastic.
9	2	45335	Permeate Port Seal	Ethylene Propylene - O - Ring
10	2	45242	Port Retainer	300 Series SST
HEAD INTERLOCK				
11	2	45260	Retainer Ring	316 L Stainless Steel.
VESSEL SUPPORT				
12	* 3	45058	Saddle	Cast Urethane Elastomer
13	* 3	47459	Strap Assy.	304 Stainless Steel-PVC Cushion.
ELEMENT INTERFACE				
14	2	A/R	Adapter	Engineering Thermoplastic.
15	2	45296	PWT/Adapter seal	Ethylene Propylene - O - Ring

* 2 each furnished with length code 1,2 & 3.

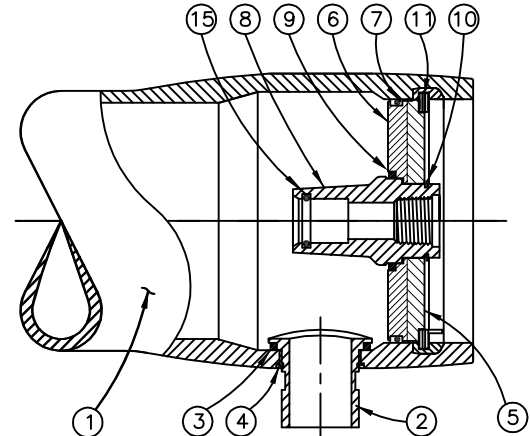
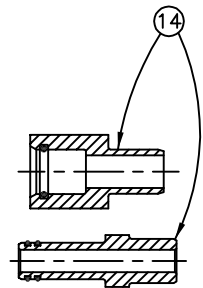

SECTION THROUGH END CLOSURE
 (ENDS ARE IDENTICAL)

• DIMENSIONS IN INCHES (MM APPROX)
 • NOT TO BE USED FOR CONSTRUCTION UNLESS CERTIFIED
 • GRADE CF3M AS PER ASME SA-351

Dash Length	L IN(MM)	P IN(MM)	S IN(MM)	Approx Weight LB(KG)
-1	48.50 (1232)	42 (1067)	25X1 (635)	14.4 (6.5)
-2	88.50 (2248)	82 (2083)	56X1 (1422)	20.4 (9.2)
-3	128.50 (3264)	122 (3099)	80X1 (2032)	27.9 (12.7)
-4	168.50 (4280)	162 (4115)	64X2 (1626)	35.4 (16.1)
-5	208.50 (5296)	202 (5131)	78X2 (1981)	42.9 (19.5)
-6	248.50 (6312)	242 (6147)	92X2 (2337)	50.4 (22.9)



CODELINE - 40S60
MEMBRANE HOUSING

DRAWN DATE	MID 02APROB	ECN 1927	DWG. NO.	99313	REV. H
CHECKED DATE	MID 02APROB		DATE	21AUG10	SCALE NONE
APPROVED DATE	SS 02APROB	DATE	21AUG10	SCALE NONE	SIZE A3

SHEET 1 OF 2

4

3

2

1

A

A

RATING:

DESIGN PRESSURE..... 600 PSI at 120°F
(4.137 MPa at 49°C)
 MIN. OPERATING TEMP..... 20°F
(-7°C)
 FACTORY TEST PRESSURE..... 660 PSI
(4.551 MPa)
 BURST PRESSURE..... 3600 PSI
(24.8 MPa)

INTENDED USE

The Model 40S60 Fiberglass RO/UF Pressure Vessel is designed for continuous, long-term use as a housing for reverse osmosis and ultrafiltration elements in typical industrial water treatment systems at pressures up to 600 psi. Any make of 4-inch nominal diameter spiral-wound element is easily accommodated. The appropriate interfacing hardware for the element specified is furnished with the vessel.

The Model 40S60 is designed in accordance with the engineering standards of the Boiler and Pressure Vessel Code of the American Society of Mechanical Engineers (ASME Code). At a small additional cost, vessels can be inspected during construction by an ASME Authorized Inspector and ASME Code stamped.

The Model 40S60 must be installed, operated and maintained in accordance with the precautions listed and good industrial practice to assure safe operation over a long service life.

The high performance reinforced plastic shell must be allowed to expand under pressure; undue restraint at support points or piping connections can cause leaks to develop in the shell. This side-ported vessel requires special precautions in mounting and connection to piping so that the vessel will not be subjected to excessive stress due to bending moments acting at the side openings in the fiberglass shell.

The end closures, incorporating close-fitting, interlocking components, must be kept dry and free of corrosion; deterioration can lead to catastrophic mechanical failure of the heads.

Pentair Water will assist the purchaser in determining the suitability of this standard vessel for their specific operating conditions. The final determination however, including evaluation of the standard materials of construction for compatibility with the specific corrosive environment, shall be the responsibility of the purchaser. Alternate materials with enhanced corrosion resistance are available on special order.

Specifications subject to change without notice.

PRECAUTIONS

- DO... read, understand and follow all instructions; failure to take every precaution will void warranty and may result in vessel failure
- DO... mount shell on horizontal members at central span "S" using compliant vessel supports furnished; tighten hold down straps just snug.
- DO... align and center side ports with the manifold header; correct causes of misalignment in a row of vessels connected to the same header
- DO... use flexible type grooved-end pipe couplings, Victaulic® Style 75 or equal, at sideports; allow full .125 inch gap between port and piping, and position piping to maximize flexibility of connection
- DO... provide flexibility in, and support for piping manifold so that vessel can grow in length under pressure without undue restraint; provide additional flexible joints in large pipes leading to manifold header
- DO... provide overpressure protection for vessel set at not more than 105% of design pressure
- DO... inspect end closures regularly; replace components that have deteriorated and correct causes of corrosion
- DO NOT... work on any component until first verifying that pressure is relieved from vessel
- DO NOT... make rigid piping connections to ports or clamp vessel in any way that restricts growth of fiberglass shell under pressure; ▲ DIA = 0.01 in. (0.25 mm) and ▲ L = .140 in. (3.5 mm) for a length code -8 vessel
- DO NOT... hang piping manifolds from ports or use vessel in any way to support other components
- DO NOT... operate vessel at pressures and temperatures in excess of its rating
- DO NOT... operate vessel without Permeate Ports internally connected with a complete set of elements and interconnecting hardware
- DO NOT... tighten Permeate Port connection more than one turn past hand tight
- DO NOT... operate vessel with permeate pressure in excess of 125 psi at 120°F (0.9 MPa at 49°C)
- DO NOT... tolerate leaks or allow end closures to be routinely wetted in any way
- DO NOT... pressurize vessel until double checking to verify that the Retaining Rings are in place.
- DO NOT... install Spacer on downstream end of vessel

NOTE

Spiral Retaining Ring Removal Tool (1MM007-1) recommended to open and close vessel.

ORDERING

Using the chart below, please check the features you require and fax them with your purchase order to our customer service department for expedited processing. For optional materials and or feature not listed below, please consult the factory for pricing and availability.

VESSEL LENGTH CODE - please check one
MODEL 40S60 -1 -2 -3 -4 -5 -6

EXTERIOR FINISH - please check one
 Standard - white high-gloss polyurethane coating over sanded surface.

CERTIFICATION - please check one
 Standard - certified by CodeLine, not code stamped.
 Option - Certified by ASME Authorized Inspector, Code stamped and registered with National Board. Call factory for pricing details.

MEMBRANE BRAND AND MODEL - please check one and fill in information

- Please supply adapters for the following membrane brand and specific model.
 Brand _____ Model _____
- Membrane brand and model information is not currently available, but will be supplied to CodeLine on or before the following date. ____/____/____

Serial number end
 Opposite end

PERMEATE PORT MATERIAL

Standard - PET
 Option - PVC (120°F maximum)
 Option - 316 Stainless Steel

PERMEATE PORT CONFIGURATION

Standard - 1/2" NPT Female (Standard per drawing)
 Option - 1/2" BSP/JIS Female

FEED PORT CONFIGURATION

Standard - 1" IPS Victaulic, 316 Stainless Steel (Standard per drawing)
 Optional - Multi-Ports™; increased port diameter or port clogging. please fill out your feed port configuration in the space below. List port location first followed by port size for each choice.

Serial number end

Opposite end

PORT SIZE CODE	
A	3/4" NPT FEMALE
B	3/4" BSP/JIS FEMALE
C	1" GROOVED END

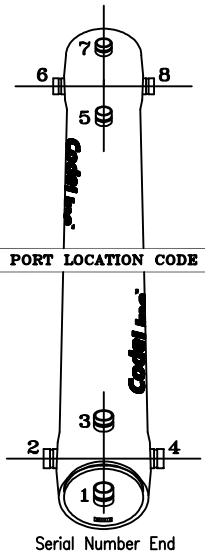

Please note that we require your membrane brand and model number when ordering. If this information is not initially available, you may provide it at a later date by checking the appropriate box below