

LKH Centrifugal Pump Description Code

Central States Industrial
 2700 Partnership Boulevard
 Springfield, MO 65803
 800.654.5635
<http://www.csidesigns.com>



Consider the information below when selecting an LKH pump.

Note: The configuration shown below will not reflect the actual model number shown on the Customer Order Acknowledgement.

1
2
3
4
5
6
7
8
9
10
11
12
13
14
15
16
17
18
19

LKH 25 M 165 S 2 E S 21 A B N - 010 A 36 T S A

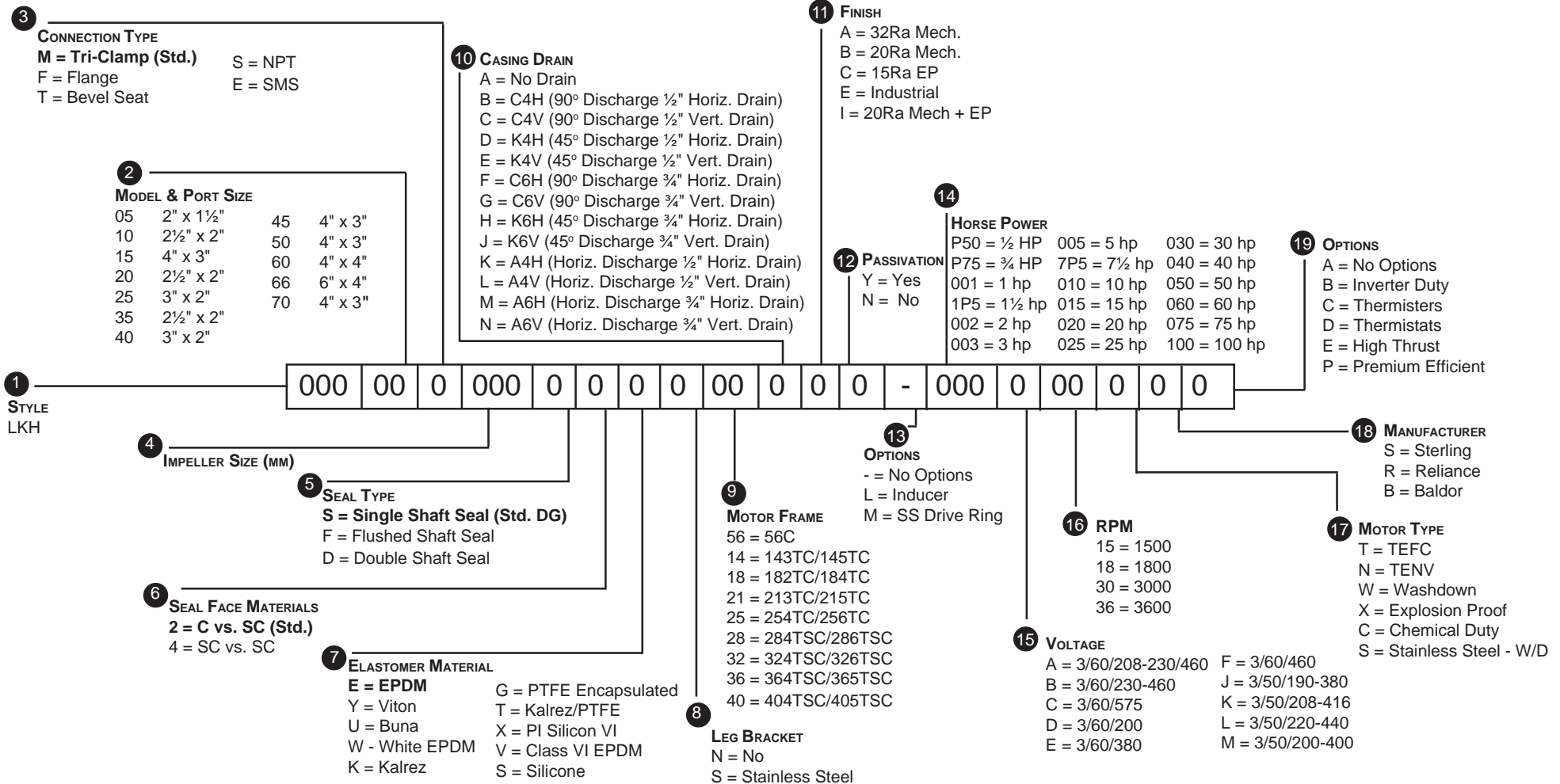

* Refer to tables for impeller sizes available per model types.

** Other options available upon request.

All motors will have locked bearings to limit axial shaft movement to .012" or less.

The LKH 70 will have special high thrust bearings.

LKHU Ultrapure Centrifugal Pump Description Code

Central States Industrial
 2700 Partnership Boulevard
 Springfield, MO 65803
 800.654.5635
<http://www.csidesigns.com>



Consider the information below when selecting an LKHU pump.

Note: The configuration shown below will not reflect the actual model number shown on the Customer Order Acknowledgement.

1 2 3 4 5 6 7 8 9 10 11 12 13 14 15 16 17 18 19 20
LKHU 25 M 165 S 4 V S 21 A I N N - 010 B 36 W S A

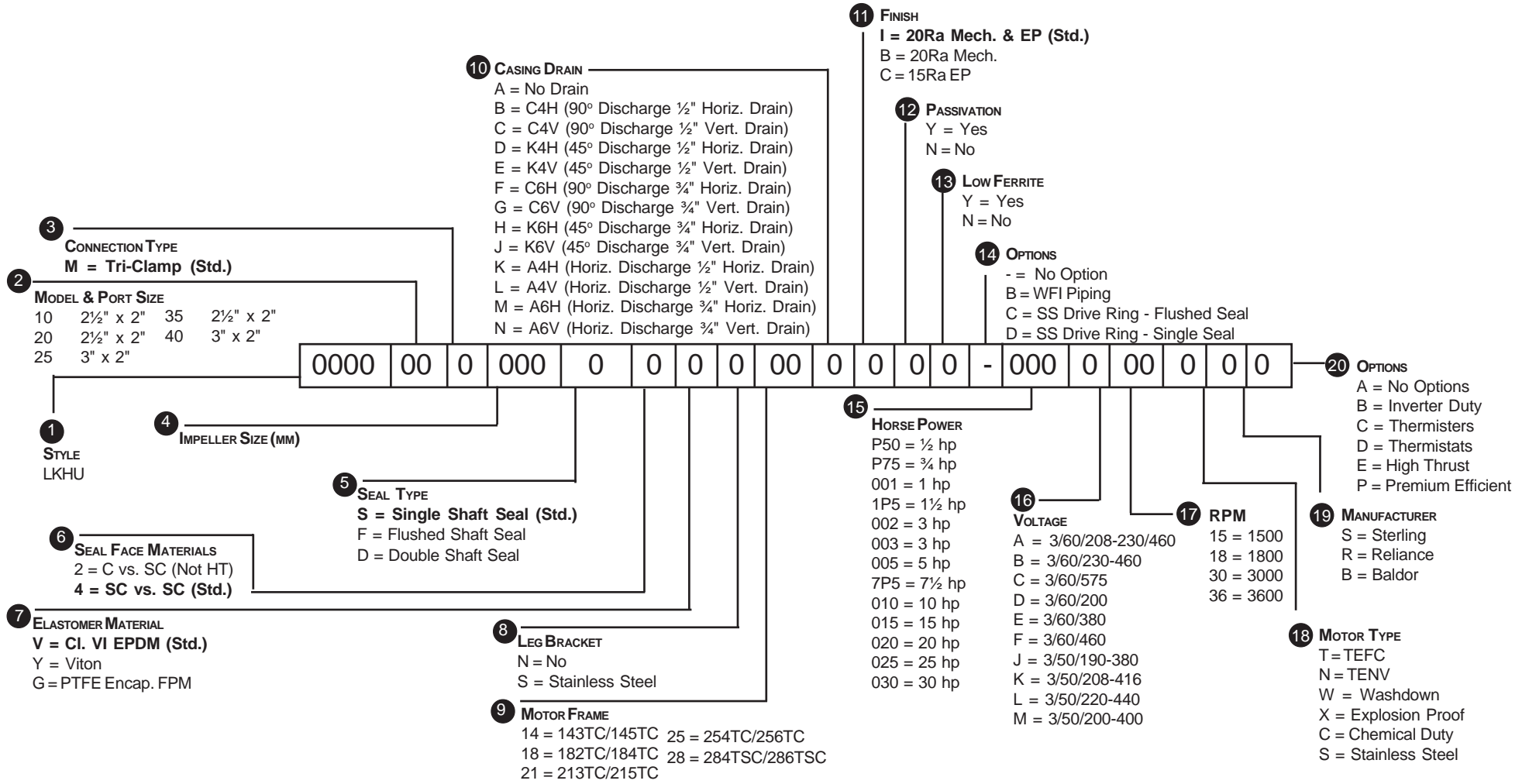

* Refer to tables for impeller sizes available per model types. ** Other options available upon request.
 All motors will have locked bearings to limit axial shaft movement to .012" or less.



LKHP Centrifugal Pump Description Code

Central States Industrial
 2700 Partnership Boulevard
 Springfield, MO 65803
 800.654.5635
<http://www.csidesigns.com>



Consider the information below when selecting an LKHP pump.

Note: The configuration shown below will not reflect the actual model number shown on the Customer Order Acknowledgement.

1
2
3
4
5
6
7
8
9
10
11
12
13
14
15
16

LKHP 10 M 000 S 4 E N 56 A - 001 A 15 T S A

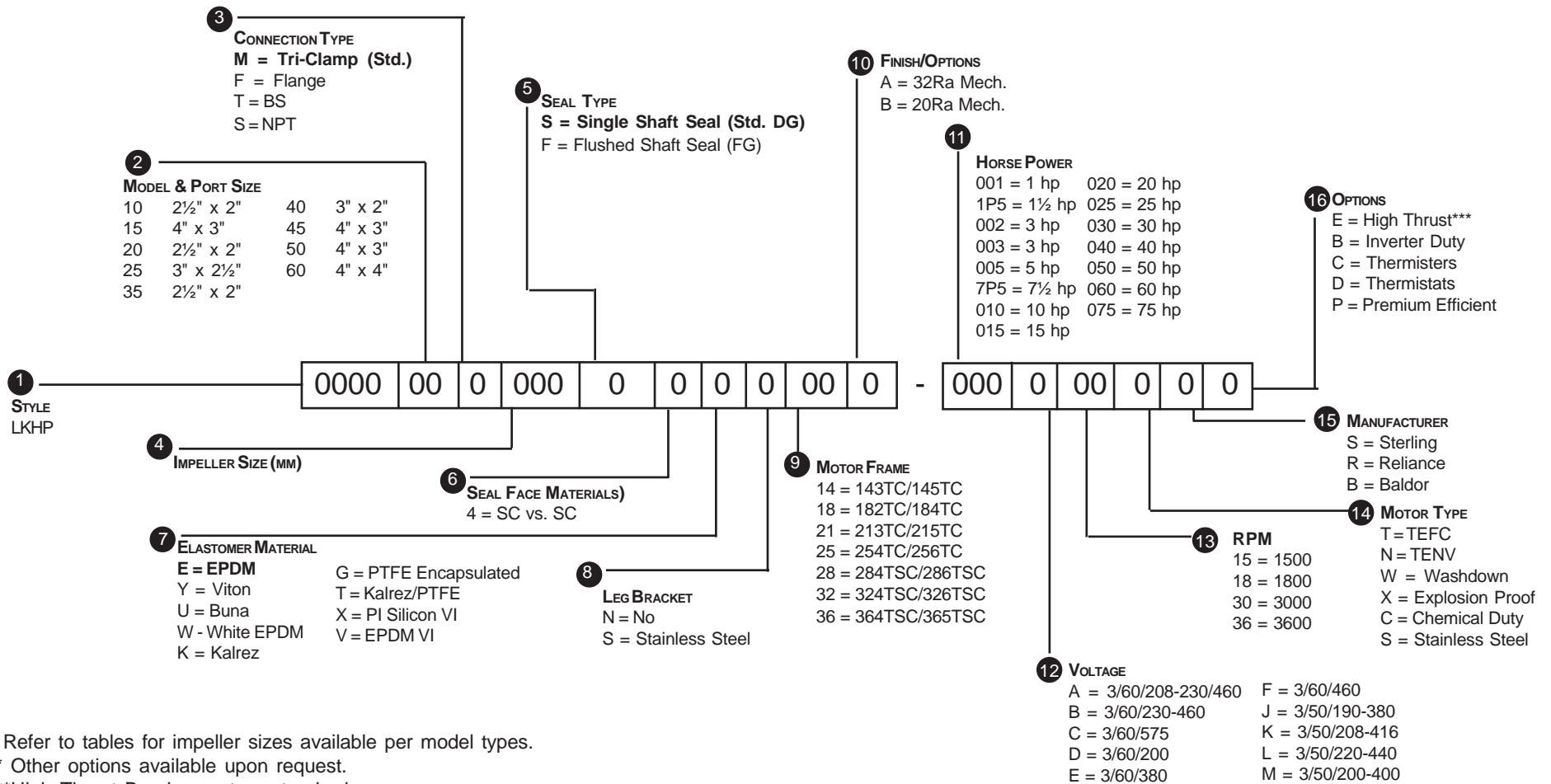

* Refer to tables for impeller sizes available per model types.
 ** Other options available upon request.
 ***High Thrust Bearing motors standard
 All motors will have locked bearings to limit axial shaft movement to .012" or less.

LKHM Multi-Stage Centrifugal Pump Description Code

Central States Industrial
 2700 Partnership Boulevard
 Springfield, MO 65803
 800.654.5635
<http://www.csidesigns.com>



Consider the information below when selecting an LKHM pump.

Note: The configuration shown below will not reflect the actual model number shown on the Customer Order Acknowledgement.

1 2 3 4 5 6 7 8 9 10 11 12 13 14 15
LKHM M 000 S 4 E N 21 A - 7P5 A 30 T S A

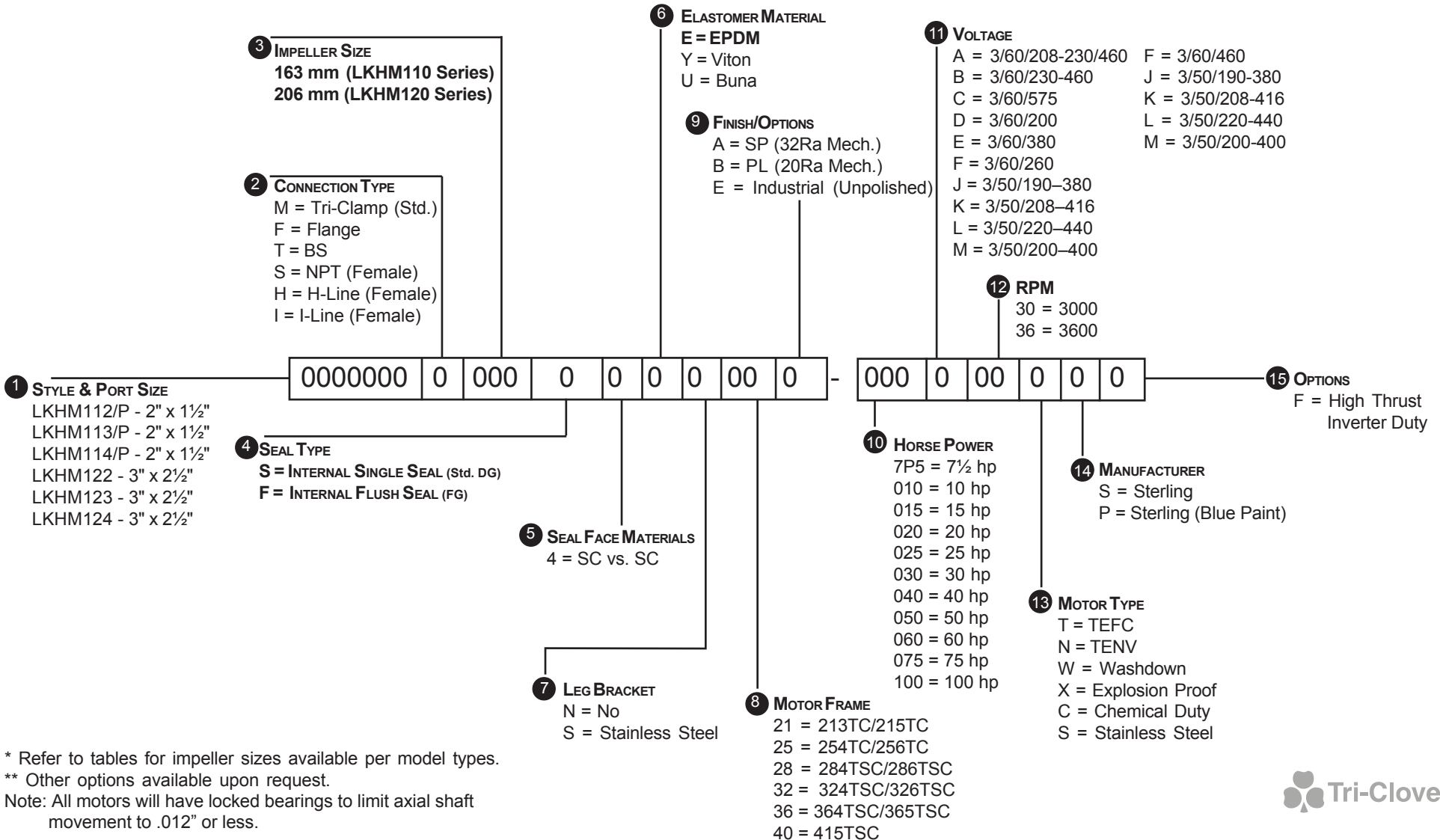

* Refer to tables for impeller sizes available per model types.

** Other options available upon request.

Note: All motors will have locked bearings to limit axial shaft movement to .012" or less.



SolidC Centrifugal Pump Description Code

Central States Industrial
 2700 Partnership Boulevard
 Springfield, MO 65803
 800.654.5635
<http://www.csidesigns.com>



1 2 3 4 5 6 7 8 9 10 11 12 13 14 15 16
C - 1 M 110 - S 2 E S 14 T 0 - 001 A - 18 W W - F F 0

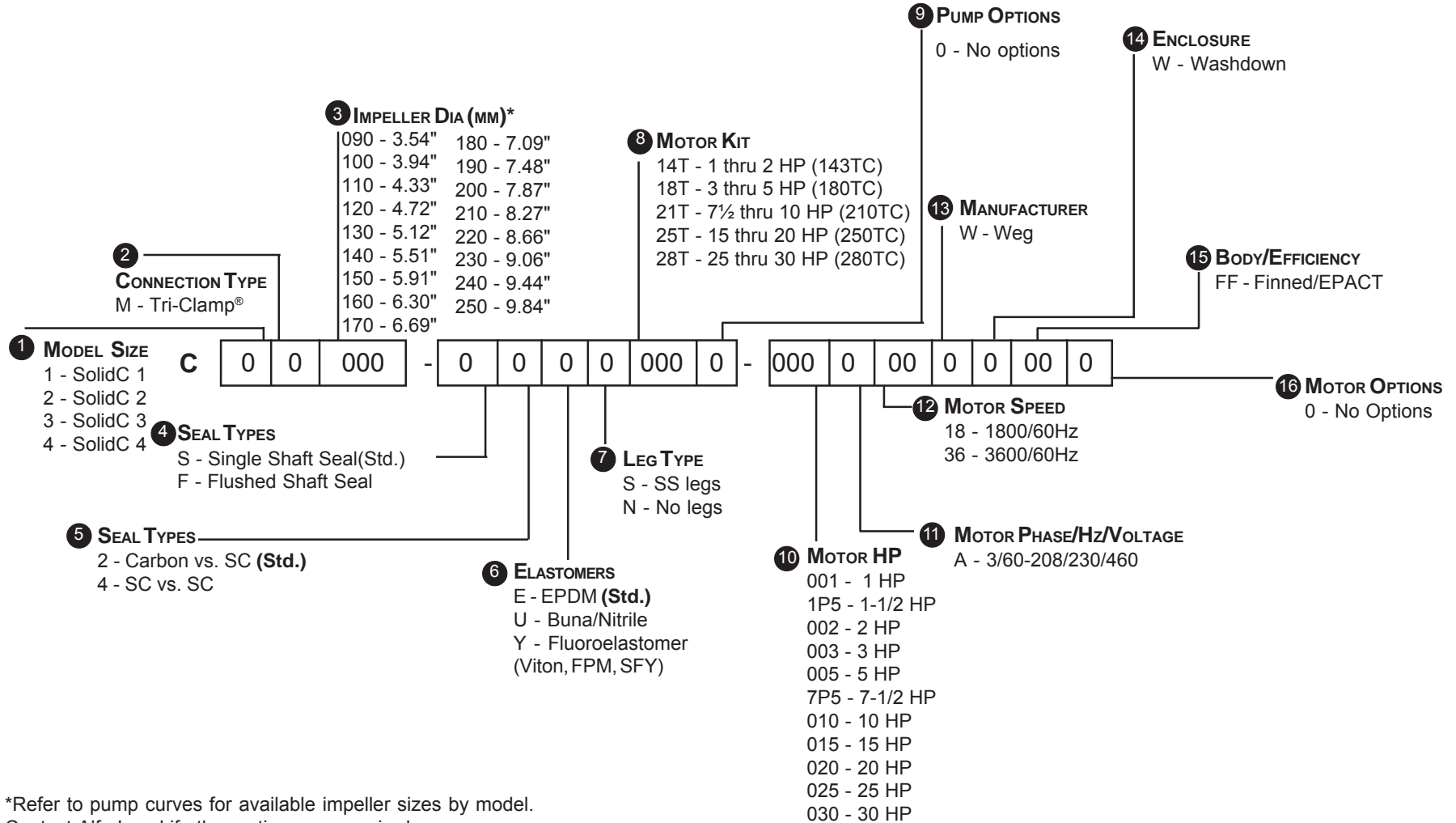

*Refer to pump curves for available impeller sizes by model.
 Contact Alfa Laval if other options are required.

LKH

Central States Industrial
2700 Partnership Boulevard
Springfield, MO 65803
800.654.5635
<http://www.csidesigns.com>



"Horizontal" Drains
K4H
K6H

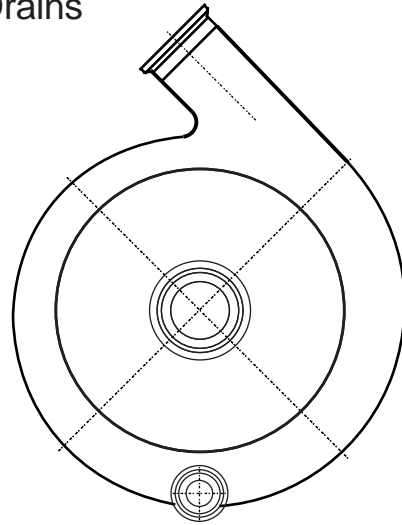
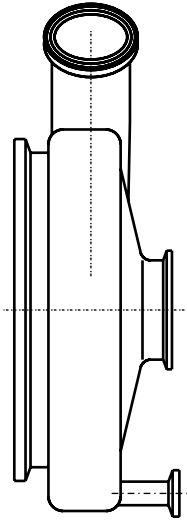

"Vertical" Drains
K4V
K6V

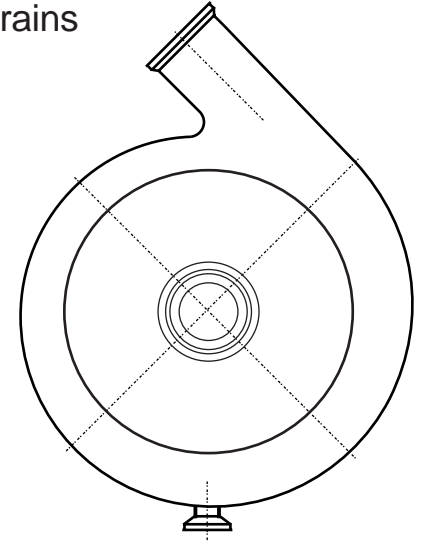
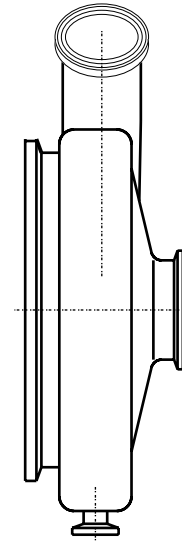

C4H
C6H

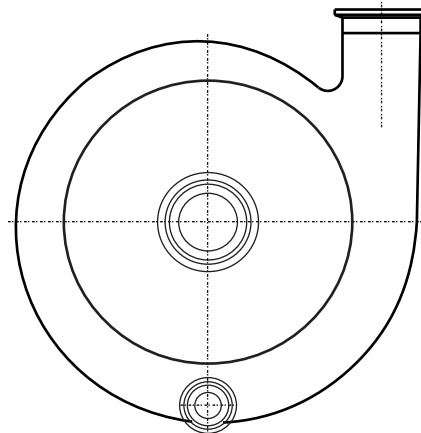
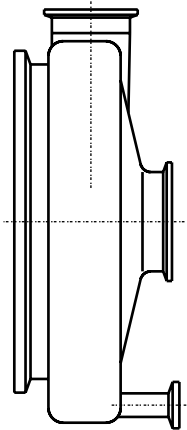

C4V
C6V

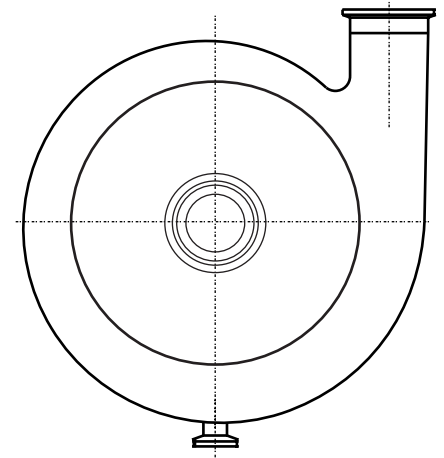
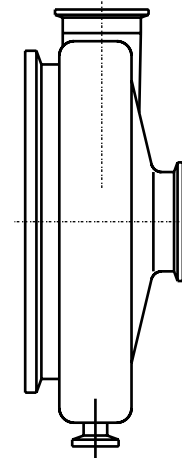

K = 45° Disch.
C = 90° Disch.

4 = 1/2" Drain
6 = 3/4" Drain

H = Horizontal
V = Vertical